

# TAI-SAW TECHNOLOGY CO., LTD.

No. 3, Industrial 2nd Rd., Ping-Chen Industrial District,  
Taoyuan, 324, Taiwan, R.O.C.

TEL: 886-3-4690038 FAX: 886-3-4697532

E-mail: [tstsales@mail.taisaw.com](mailto:tstsales@mail.taisaw.com) Web: [www.taisaw.com](http://www.taisaw.com)

## Product Specifications Approval Sheet

Product Description: Crystal Unit HC49SMD 7.3728MHz

TST Part No.: TZ2775A

Customer Part No.: \_\_\_\_\_

Customer signature required
Company: _____
Division: _____
Approved by : _____
Date: _____

Checked by: \_\_\_\_\_ Ginger Huang *Ginger Huang*

Approved by: \_\_\_\_\_ Kelly Huang *Kelly Huang*

Date: \_\_\_\_\_ 07/24/2013

1. Customer signed back is required before TST can proceed with sample build and receive orders.
2. Orders received without customer signed back will be regarded as agreement on the specifications.
3. Any specifications changes must be approved upon by both parties and a new revision of specifications shall be released to reflect the changes.



**TAI-SAW TECHNOLOGY CO., LTD.**  
**HC49SMD 7.3728MHz Crystal Unit**

MODEL NO.: TZ2775A

REV. NO.: 1.0

**Revise:**

Rev.	Rev. Page	Rev. Account	Date	Ref. No.	Reviser
1	N/A	Initial release	07/24/13'	N/A	Ginger Huang



# TAI-SAW TECHNOLOGY CO., LTD.

No. 3, Industrial 2nd Rd., Ping-Chen Industrial District,  
Taoyuan, 324, Taiwan, R.O.C.

TEL: 886-3-4690038 FAX: 886-3-4697532

E-mail: [tstsales@mail.taisaw.com](mailto:tstsales@mail.taisaw.com) Web: [www.taisaw.com](http://www.taisaw.com)

## HC49SMD 7.3728MHz Crystal Unit

MODEL NO.: TZ2775A

REV. NO.: 1.0

### Features:

- Good Frequency Perturbation and Stability over temperature

RoHS Compliant

Lead-free soldering

### Description and Applications:

HC49SMD crystal unit for use in wireless telecommunications devices

### Electrical Specifications:

TZ2775A	Specification
Nominal Frequency	7.372800MHz
Mode of Oscillation	Fundamental
Storage Temperature Range	-40°C~+85°C
Operating Temperature Range	-10°C~+70°C
Frequency Stability over Operating Temperature Range	+/-30 ppm (referred to the value at 25°C)
Frequency Make Tolerance (FL)	+/-30 ppm @ 25°C +/- 3°C
Equivalent Series Resistance (ESR)	50 Ω max
Nominal Drive Level	100 uW
Shunt Capacitance (Co)	5.0 pF max
Load Capacitance (CL)	16 pF
Aging	+/-3.0 ppm/year
Insulation Resistance	500 MΩ min./DC 100V
Marking	Laser marking

## Mechanical Dimensions (mm):

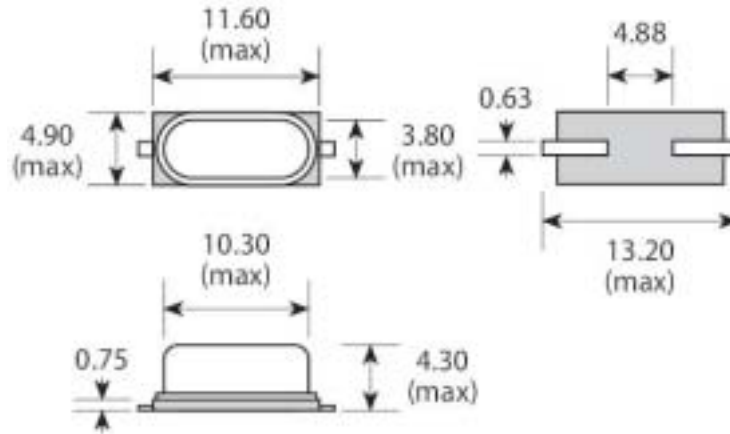

## Marking:

Line 1: Frequency (7.372)

Line 2:TST Logo + Date Code("Z" for product code and "D" for date code) + Traceability Code(XX)



## Product Code Table

Year	2009	2010	2011	2012
	2013	2014	2015	2016
	2017	2018	2019	2020
product code	Z	z	<u>Z</u>	<u>z</u>

## Date Code Table

WK01	WK02	WK03	WK04	WK05	WK06	WK07	WK08	WK09	WK10	WK11	WK12	WK13
A	B	C	D	E	F	G	H	I	J	K	L	M
WK14	WK15	WK16	WK17	WK18	WK19	WK20	WK21	WK22	WK23	WK24	WK25	WK26
N	O	P	Q	R	S	T	U	V	W	X	Y	Z
WK27	WK28	WK29	WK30	WK31	WK32	WK33	WK34	WK35	WK36	WK37	WK38	WK39
a	b	c	d	e	f	g	h	i	j	k	l	m
WK40	WK41	WK42	WK43	WK44	WK45	WK46	WK47	WK48	WK49	WK50	WK51	WK52
n	o	p	q	r	s	t	u	v	w	x	y	z

## PACKING:

### 1. REEL DIMENSION (Unit: mm)

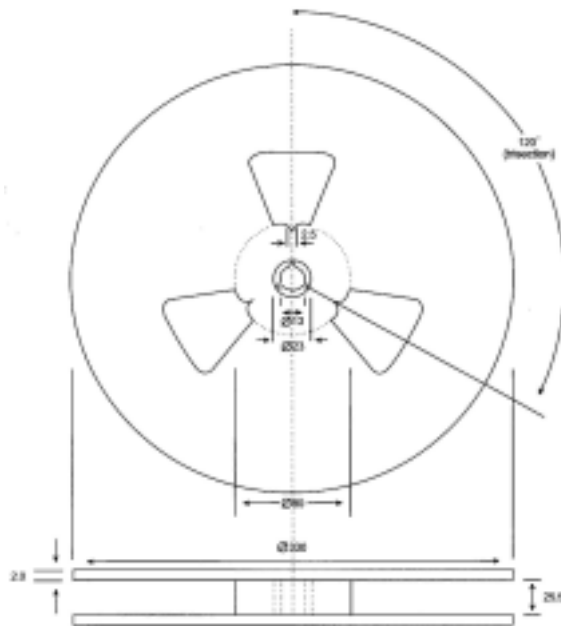

### 2. TAPE DIMENSION (Unit: mm)

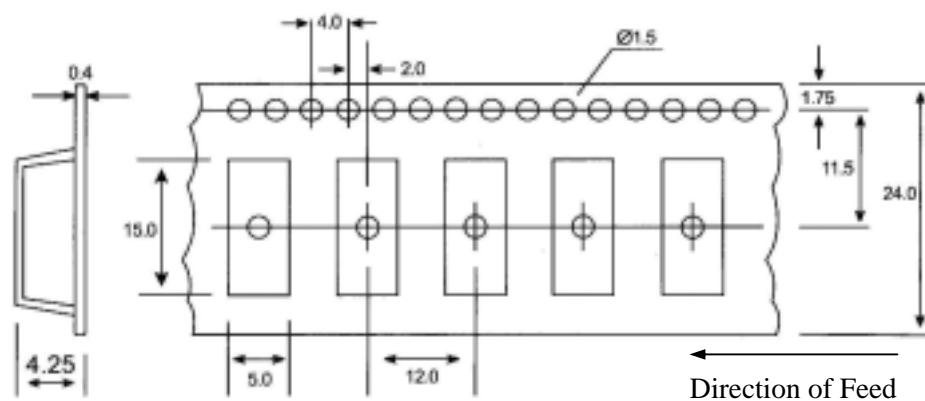

## Reflow Profile:

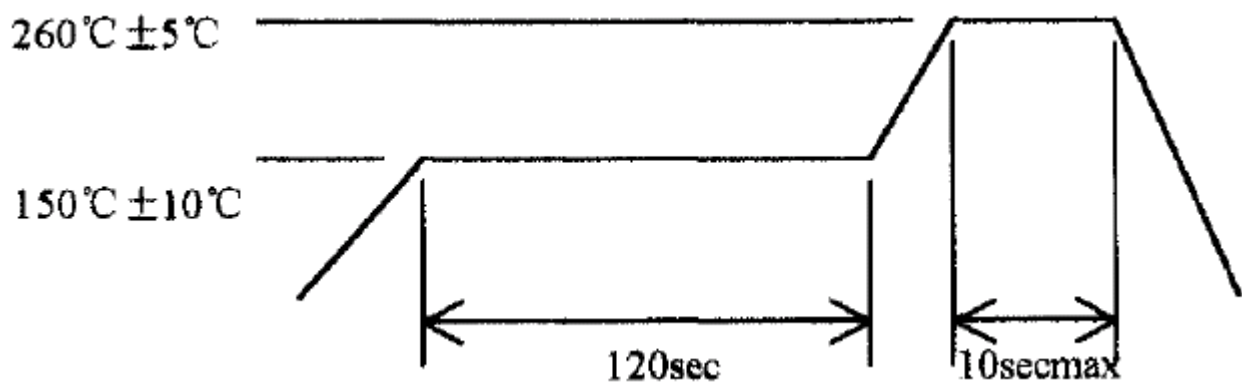

Note: 1. Max peak temperature: 260±5 deg C; Time: 10±2 sec

2. Temperature: 150±10 deg C; Time: 120 sec

